

CVS

Controls Ltd.

INSTRUCTION MANUAL

CVS Series 95H Pressure Reducing Regulator

The CVS Series 95H regulator is a directly operated pressure reducing regulator suitable for controlling air, gas, liquids, steam and other similar process which require constant outlet pressures.

The Series 95H is a high-pressure regulator with three different available outlet spring ranges from 15 psig to 150 psig. Maximum inlet pressure available is 300 psig standard configuration.

Shutoff classification is Class IV, with metal seats.

Body materials available are cast iron, steel and stainless steel. Body sizes available are 3/4" and 1" NPT with 9/16" orifice.

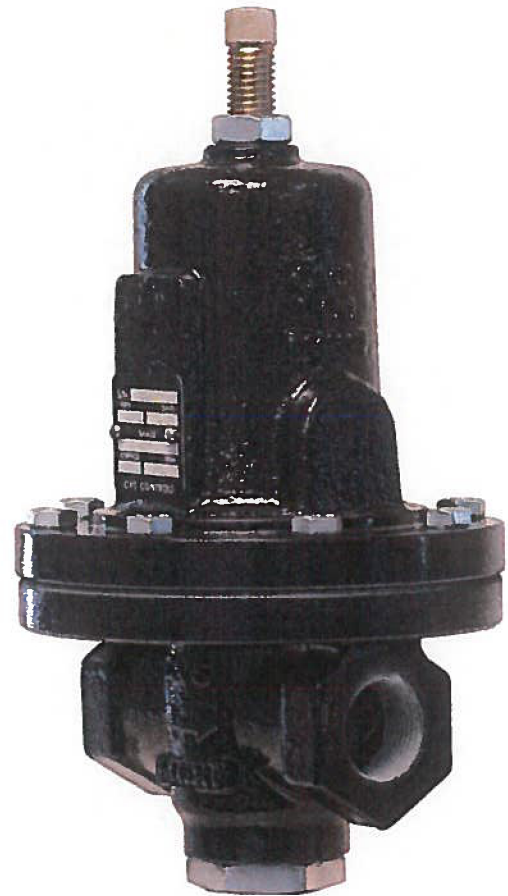

CVS Series 95H Regulator

SPECIFICATIONS

Series 95H: 15 to 150 psig outlet pressure range, High Pressure Regulator

Body and Orifice:

3/4" and 1" NPT end connections with 9/16" orifice

Max Temperature Range of Body Materials:

Steel LCC: -50°F to 650°F (-50°C to 340°C)

Max Temperature Range – Diaphragm and Seat Material:

Stainless Steel, 302: -40°F to 650°F (-40°C to 343°C)

Shutoff Classification:

Class IV, Metal Seat

Pressure Setting Adjustments:

Standard, Adjustment Screw

Pressure Registration:

Internal

Approximate Shipping Weight:

3/4" and 1" Bodies – 20lbs (9kg)

INSTALLATION

Ensure all debris is free and clear of the regulator. Inspect for any damage which may have occurred during shipping prior to installation. Clean all pipelines, apply piping compound to the external threads and install the regulator in any position required for the application. Verify flow direction through the body of the regulator by the flow arrow as indicated on the lower regulator body.

****When installation of the regulator is complete, it is important that the vent hole on the spring case remains unobstructed at all times. If installed outdoors, the regulator should be installed to prevent water, ice and any foreign materials from obstruction the vent.**

Overpressure protection is needed should the inlet pressure exceed the maximum operating outlet pressures.

The CVS 95H Regulator is set to customer specifications indicated during ordering. Once properly installed, no initial adjustments should be required. Slowly open process connections and inspect for any leakage.

ADJUSTMENTS AND MAINTENANCE

Adjustments are easily done within the selected spring range. Refer to the nameplate for outlet range.

To change the outlet pressure:

1. Loosen the Locknut (15) on the Adjusting Screw (1)
2. Turn the Adjusting Screw clockwise to increase the outlet pressure within the spring range
3. Turn the Adjusting Screw counter clockwise to decrease the outlet pressure range
4. Use a test gauge to monitor the outlet pressure. Once desired pressure is achieved tighten the Locknut

****Prior to performing maintenance ensure all proper shutoff procedures have been followed and the CVS 95H has been relieved of all process pressure.**

Maintenance

Certain operating conditions may require increased inspection intervals. Inspect the regulator for improper operation or damage to determine if repair or replacement is required.

Disassembly and Inspection:

1. Remove the Valve Plug Guide (10) from the regulator Body (7). The Valve Plug Spring (11) and the Valve Plug (9) will come out with the removal of the Valve Plug Guide.

Inspect components for signs of damage or wear. Note condition of the Valve Plug Seating Surface. Replace as required.

2. Looking from the bottom of the regulator, inspect the Orifice (12). If the orifice shows signs of damage or wear, replace as required by unscrewing it from the regulator body. Torque the Orifice to 33-42 ft lbs when reinstalling.

If inspection is complete at this point, the CVS 95H may be reassembled in reverse of the above steps. When reinstalling the Valve Plug Guide (10), apply a suitable thread sealant. Torque the valve plug guide to 130-160 ft lbs.

Maintenance continued,

To inspect the diaphragm and other internal items:

1. Loosen the Locknut (15) and remove spring compression by turning the Adjusting Screw (1) counter clockwise.
2. Remove the Spring Case Hex Head Screws (14), lift off the Spring Case (2), Upper Spring Seat (3) and Regulator Spring (4). Remove the Lower Spring Seat (5).

Inspect for wear or damage and replace as required.

3. Lift off qty two, Metal Diaphragms (6) and inspect for damage. Replace if required.
4. Remove Diaphragm Gasket (13), replace if shows signs of wear or damage.
5. Lift out Stem Assembly (8), inspect and replace if required.
6. Visually inspect pitot tube and ensure is free and clear from any debris.

Reassemble in reverse order.

Note: When installing the 2 Diaphragms (6), place on top of the Diaphragm Gasket (13) paying close attention to the orientation of both Diaphragms. **The bevelled edge must be facing up, on both diaphragms.**

CVS Series 95H – Assembly

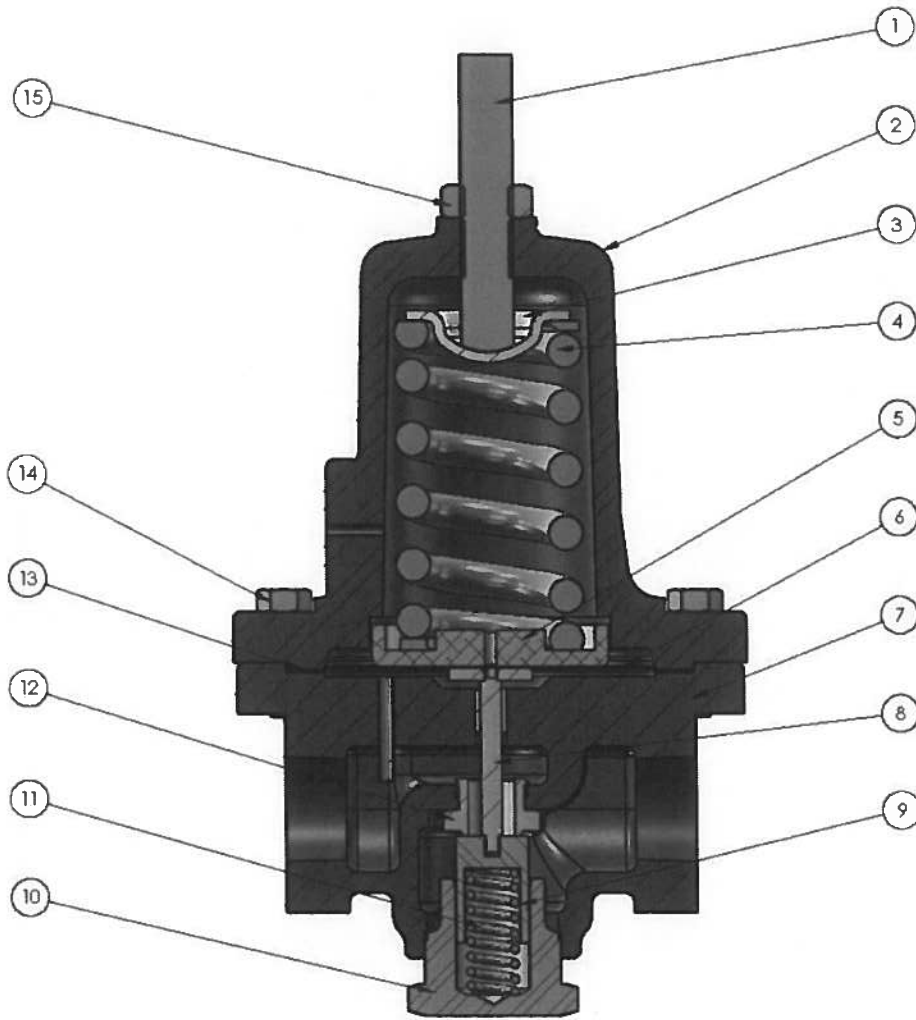

Item #	Part Number	Description	Qty
1	CVS 1A330828982	Adjusting Screw	1
2	CVS 3E397819012	Spring Case	1
3	CVS 1E398725072	Upper Spring Seat	1
4	See table	Regulator Spring	1
5	CVS 1E398608012	Lower Spring Seat	1
6	CVS 1E399241012	Diaphragm	2
7	CVS 2E397319012	Body	1
8	CVS 1F2115000A2	Stem Assembly	1
9	CVS 1E398146172	Valve Plug	1
10	CVS 1E398235132	Valve Plug Guide	1
11	CVS 1E398837022	Valve Plug Spring	1
12	CVS 1E398046172	Orifice	1
13	CVS 1E399304022	Diaphragm Gasket	1
14	CVS 1A341824052	Hex Head Screw 3/8-16 x 1-1/4	8
15	CVS 1A319224122	Hex Jam Nut 5/8-11 UNC	1

Item 4 – Upper Spring			
Outlet Pressure Range		Part #	Color
PSIG	BAR		
15-30	1.0-2.1	CVS 1E398927022	Yellow
25-75	1.7-5.1	CVS 1E399027142	Green
70-150	4.8-10.3	CVS 1E399127162	Red

Item 7 – Body Assembly	
	LCC
	NPT
3/4"	CVS 2E408422A12
1"	CVS 2E408522A12

CVS Series 95H – Dimensions - Inches

